

HP DesignJet 2500CP and 2000CP Printers

Data Sheet

Photo-quality, poster-size printing

HP DesignJet 2500CP Printer

- C4704A (36-inch) \$11,995*
- Comes ready to print right out of the box—includes Adobe™ PostScript™ Level 2 print language, built-in RIP, 2 GB hard disk and HP JetDirect card with Ethernet connectivity

HP DesignJet 2000CP Printer

- C4703A (36-inch) \$9,995*
- You must provide your own RIP solution to operate the printer

Highlights

- Photo-quality images with brilliant, accurate colors and smooth, subtle skin tones
- HP DesignJet printers, ink systems, and media designed together for optimum image quality
- Revolutionary auto-replenishment ink delivery system produces higher quality output at lower cost with less intervention
- Replacement of ink system is clean and easy
- Cost per copy about \$.40 per square foot on coated paper (ink and media)
- Prints poster-size images up to 3 by 150 feet
- Built-in humidity and temperature sensor automatically adjusts dry times for best results
- Prints up to 400 2-by-3-foot prints per ink system
- Accepts a wide range of media including coated papers, photo papers, films, vinyl, and more
- 1-year warranty with free onsite service and preventative maintenance if needed for high-volume users
- HP DesignJet 2500CP only
 - Processes next file while printing another file for maximum productivity
 - Lets you reprint images in queue quickly and easily
 - PostScript Microsoft® Windows® and Macintosh drivers included
 - Automatic color calibration ensures consistent results
 - True Adobe PostScript Level 2 print language
 - PANTONE®** tables for color matching

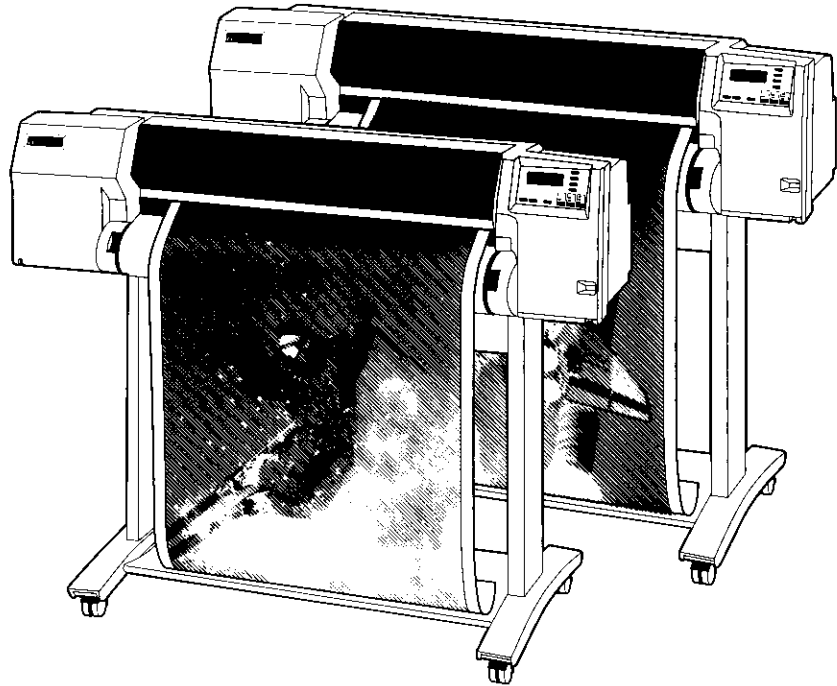

* U.S. list price

** Pantone, Inc.'s check-standard trademark for color

HP DesignJet 2500CP and 2000CP Printers

Specifications	HP DesignJet 2500CP	HP DesignJet 2000CP
Print Technology	Color Thermal Inkjet	
Throughput (2-by-3-foot print)	Fast 4 min, Normal 8 min, Best 19 min (on coated paper)	
Resolution	Best: 600 dpi, Normal: 300 dpi, Fast: 300 dpi	
Ink Sets	4 color CMYK HP DesignJet CP Ink Systems (Imaging) HP DesignJet CP Ink Systems UV (Durability) Available Fall '97	
HP DesignJet Media	HP Coated and Heavyweight Coated Paper, HP Semi-Gloss and High-Gloss Photo Paper and HP High-Gloss White Film*	
Co-Developed Media	3M Clear Imaging Media, 3M Translucent Backing, 3M Changeable Opaque Imaging Media*	
Media Handling	Roll and sheet feed, automatic cutter	
Media Sizes	8.3 to 36-in wide sheets, 24-in and 36-in rolls; Maximum length 150 ft	
Memory, Standard	20 MB RAM, 2 GB Disk	8 MB RAM
Memory, Maximum	68 MB RAM	68 MB RAM
Languages	Adobe PostScript Level 2, HP-RTL	HP-RTL
Interfaces, Standard	HP Bi-Tronics ECP, (Centronics) Ethernet/LocalTalk	HP Bi-Tronics ECP (Centronics)
Interfaces, Optional	HP JetDirect network interface cards	
Auto Interface Switching	Yes	
Front Panel Display	2 lines by 20 characters	
Warranty	1 year with free onsite service and preventative maintenance	
Physical Characteristics		
Height, Depth, Length/Weight	48 by 29 by 61 in/183 lb	
Shipping Dimensions/Weight	39 by 24 by 70 in/254 lb	
Operating Environment		
Temperature Range	Operating: 59°-86° F, Storage: -40°-158° F	
Relative Humidity	Operating: 20%-80%	
Power Requirements	100-240V AC +/- 10%, 2 A max., 50-60 Hz	
Power Consumption	120W maximum	
Sound Pressure Level	Operating: 42 dB (A), Idle: <26 dB (A)	
Sound Power Level	Operating: 5.6 Bels (A), Idle: <3.9 Bels (A)	
Certifications		
Safety	UL listed, CSA certified, NEMKO approved, NOM-1-NYCE certified, IEC 950 et al., CCIB Certified, IEC 825-1 Class 1 compliant	
Electromagnetic Interference	FCC Class B certified, EN 55022 (1988), CISPR Class B, PRen55024-2, -3, -4, C-VCCI-2, DOC Class B. Products exhibits class A operation when connected to LAN cables using print server accessories.	
Environmental	US EPA Energy Star	

* Media shown for HP DesignJet CP Ink Systems

Ordering Information

Description	HP P/N
HP DesignJet 2500CP printer	C4704A
HP DesignJet 2000CP printer	C4703A

The above units come with a roll-feed spindle, cutter knife, and holder; HP DesignJet CP ink systems—one each of black, cyan, magenta, and yellow; one roll of HP Coated Paper and one roll of HP High-Gloss White Film; User's Guide; Quick Reference Guide; Setup Guide; Assembly Instructions; Accessories Guide; Media Guide; User documentation CD-ROM; and an "HP DesignJet 2500CP and 2000CP—getting the best from your printer" CD-ROM.

The HP DesignJet 2500CP printer also includes a 2 GB hard disk, HP JetDirect card for Ethernet/LocalTalk, and PostScript drivers for Macintosh and Windows.

Supplies

Supplies	HP P/N
HP DesignJet CP Ink System:	
Black	C1806A
Cyan	C1807A
Magenta	C1808A
Yellow	C1809A
HP DesignJet Media:* (36-inch rolls)	
HP Coated Paper	C6020A
HP Heavyweight Coated Paper	C6022A
HP Semi-Gloss Photo Paper	C6024A
HP High-Gloss Photo Paper	C6026A
HP High-Gloss White Film	C3885A

Accessories

Accessories	HP P/N
HP memory expansion modules:	
4 MB SIMM	C6229A
8 MB SIMM	C6230A
16 MB SIMM	C6231A
32 MB SIMM	C6232A
Roll-feed spindle assembly	C3173A
Interface cables must be ordered separately.	

Adobe and PostScript are trademarks of Adobe Systems Incorporated which may be registered in certain jurisdictions. Microsoft and Windows are U.S. registered trademarks of Microsoft Corporation.

Technical information in this document is subject to change without notice.

© Hewlett-Packard Co. 1997
Printed in the USA 3/97
5965-7269EUS



Adobe PostScript

As an ENERGY STARSM Partner, Hewlett-Packard Company has determined that this product meets ENERGY STARSM guidelines for energy efficiency.